

Wireless Countess.

A one sixth sized indoor FF Radio Queen

All strip & sheet 1/20" balsa
except where noted otherwise.

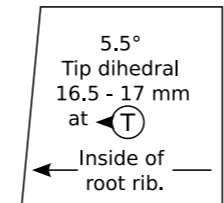
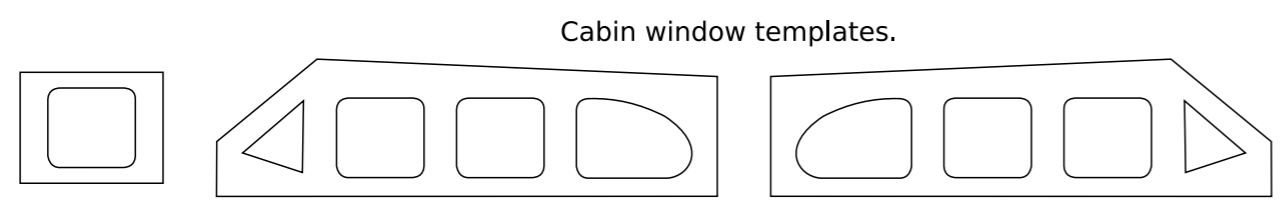
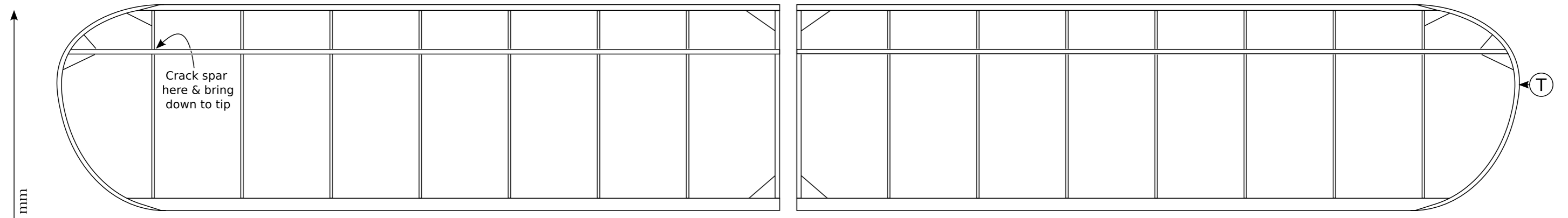
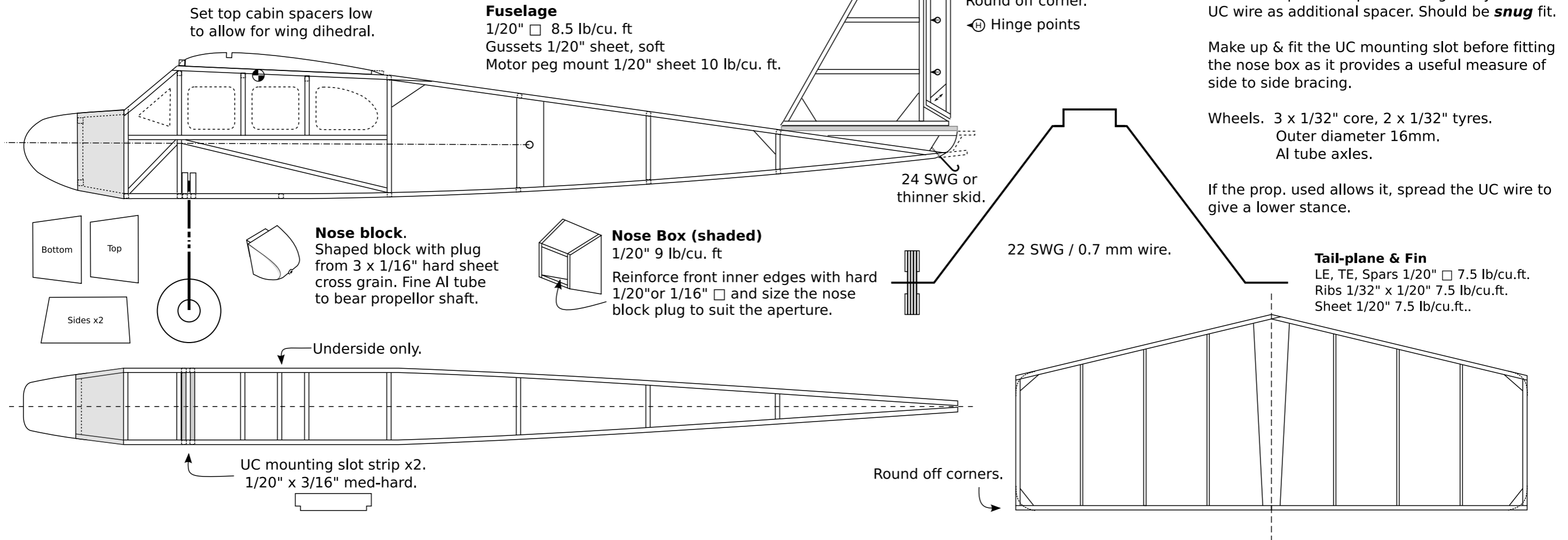

Trimming Notes

Expected Weight: ≈8g built, untrimmed
Suggested Motor: 13" loop 1/16" Tan II
Propeller : 4" Peck (VMC) Pattern
Thrust Lines : Right - ≈2°
Down - 0.5 to 1°

The suggested prop & motor will give 30 seconds from ROG on ≈1,400 turns.

Wing

LE 1/16" □ hard.
Spar 1/20" □ 10 lb/cu.ft
TE 1/20" x 1/8" 8 lb/cu. ft
Root ribs 1/20" 10 lb/cu.ft.
Remaining ribs 1/32"
Wing tips 1/32" x 1/20" bass wood.
Sheet 1/20" light ≤ 8 lb/cu. ft

Cover the flying surfaces with pre-shrunk tissue.
Dope fuselage & flying surfaces with 20-25% by volume non-shrinking dope